

SBEV-RIN32M4CL3
User's Manual
(R-IN32M4-CL3 Evaluation Board)
Ver 1.0

Document No. 30125A001E

Date Published Dec, 2020

Shimafuji Electric Inc.

Printed in Japan

This board is for research and

- The content of this document is subject to change without prior notice.
- The evaluation board described in this document is made available for research and development.
- This information contained herein may not be reprinted or duplicated without written notice from Tessera Technology, Inc. (Tessera).
- Tessera does not guarantee or grant licenses to the intellectual property or other rights of Tessera or any third party for use of this material or the products described in this document.
Tessera does not bear any responsibility if a problem occurs related to the ownership rights of third parties arising from the use of the above-described products or information.
- The information contained in this document is intended to illustrate the operation of semiconductor products and application examples. Therefore, customers using this information in the design of their own equipment must take full responsibility for product design.

Revision history

Revision	Date	Description	Note
Ver 1.0	2020/10/17	Initial version	

Table of contents

Table of contents	2
1. Overview	3
2. Specifications	3
3. Board Block Diagram	4
4. Feature Description	5
4.1. R-IN32M4-CL3	5
4.2. Operation Mode Selection	5
4.3. JTAG (ICE) Interface	5
4.4. External Memory (Serial Flash)	6
4.5. I2C Interface	6
4.6. CSI Interface	6
4.7. RS-485 Interface	7
4.8. UART Interface	7
4.9. General-Purpose I/O	8
4.10. CC-Link IE TSN / CC-Link IE Field Interface	9
4.11. Power Supply	10
4.12. Reset	10
4.13. Clocks	11
5. DIP, Rotary, and Push Switch Configurations	12
5.1. SW1: Mode Setting	12
5.2. SW12 General-Purpose Port DIP Switch	12
5.3. SW3 / SW5 CC-Link IE TSN IP address Selection Rotary Switches / CC-Link IE Field Station Number Selection Rotary Switches	13
5.4. SW13 Reset Push Switch	13
6. LED	14
6.1. Power Supply	14
6.2. LEDs for Monitoring CC-Link IE TSN / CC-Link IE Field Operations	14
6.3. General-purpose LED	14
7. Connector Pin Definitions	15
7.1. I2C Connector	15
7.2. CSI Connector	15
7.3. RS-485 Connector	16
7.4. UART (USB) Connector	16
7.5. CC-Link IE TSN / CC-Link IE Field Connector	17
7.6. JTAG (ICE) Connector	18
7.7. DC Power Jack	18
8. Table of Pad Connection Pins	19
8.1. PAD Connection Pins	19
9. Default Factory Settings	19
9.1. DIP-SW/Rotary-SW	19
5. Board External Diagram	20

1. Overview

“SBEV-RIN32M4CL3” board is for evaluation of industrial LSI "R-IN32M4-CL3" made by Renesas Electronics. Evaluation platform.

2. Specifications

Item	Specification		
Main ASSP *1	Renesas Electronics System LSI R-IN32M4-CL3 ARM Cortex™-M4 32-bit RISC CPU with HW-RTOS (Hardware Real-Time OS) 1.3M-byte Large-capacity RAM Operating frequency 100MHz		
Ext. Memory	Flash memory (Serial)	64M-bit (Quad), MX25L6433FM2I-08G equivalent	
インターフェース	I2C	1ch	4×1Pin 2.54mm Header
	CSI	1ch	5×1Pin 2.54mm Header
	RS-485	1ch	5×1Pin 2.54mm Header
	UART	1ch (UARTtoUSB)	USB micro-B connector *2
	CC-Link IE TSN CC-Link IE Field	2ch	RJ45
	JTAG(ICE)	1ch	20-pin half-pitch connector (Trace supported)
LED	Power Supply	1 green LED	
	CC-Link IE TSN CC-Link IE Field Monitor	3 red / 4 green LEDs	
	RJ45 Monitor	1 green / 1Yellow LED per ch	
	General-purpose interface	2 green / 2 red LEDs	
DIP-SW	Operation mode selection	2 bits (SW1)	
	General-purpose interface	4 bits (SW12)	
Rotary SW	CC-Link IE TSN IPselection CC-Link IE Field station selection	Two 16-way rotary switches (0 to F)	
Power Supply	AC Adapter / USB / ICE	DC +5.0V±5%	
Operation Temp.	0 to +50°		

table 2.2. Specifications

*1 ASSP means “Application Specific Standard Product,” a standard System LSI. Please refer to the Renesas datasheet and user’s manual for details concerning R-IN32M4-CL3.

*2 The USB cable must be inserted and detached while the board is powered.

3. Board Block Diagram

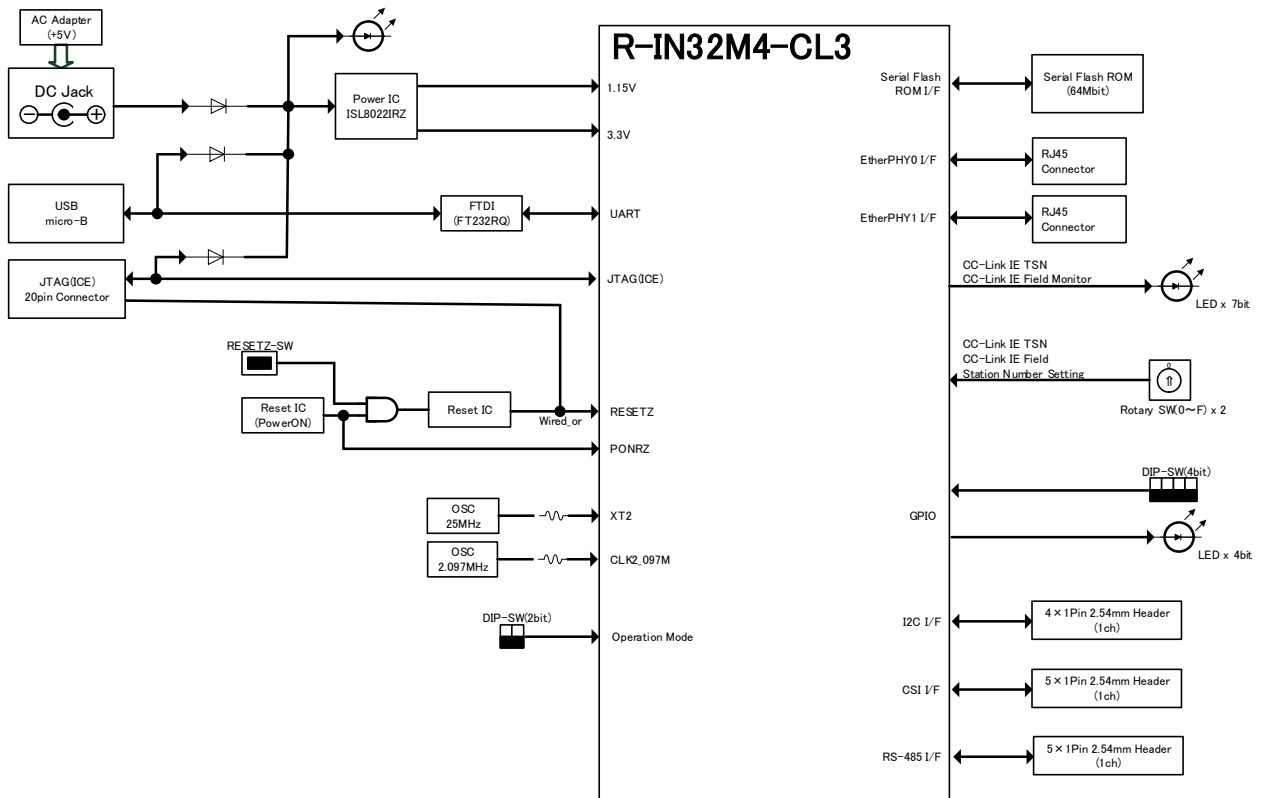

Figure 3 Board Block Diagram

4. Feature Description

4.1. R-IN32M4-CL3

Refer to the corresponding Renesas Electronics Corp. datasheet and user's manual for more details.

4.2. Operation Mode Selection

An 2-bit DIP switch (SW1) is provided for operation mode selection.

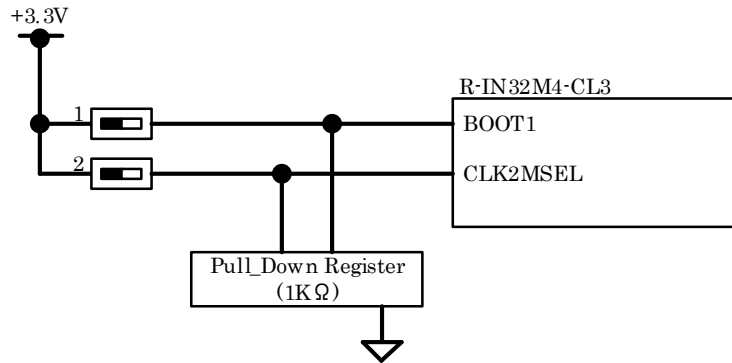

4.3. JTAG (ICE) Interface

The JTAG (ICE) connector is available for the on-board CPU (R-IN32M4-CL3). The connector is a 10 x 2 pin header with 1.27 mm pitch.

*To prevent incorrect insertion, the 7th pin is pulled out.

*Signal TRSTZ is wired-OR connected to signal RESETZ pin.

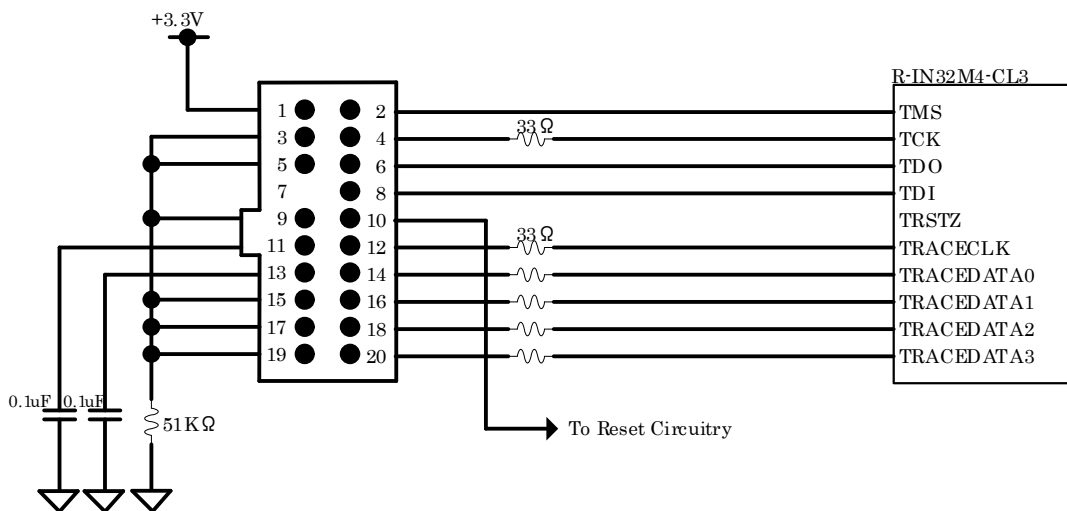

4.4. External Memory (Serial Flash)

A serial flash memory (MX25L6433FM2I-08G equivalent) is used to boot the internal CPU.

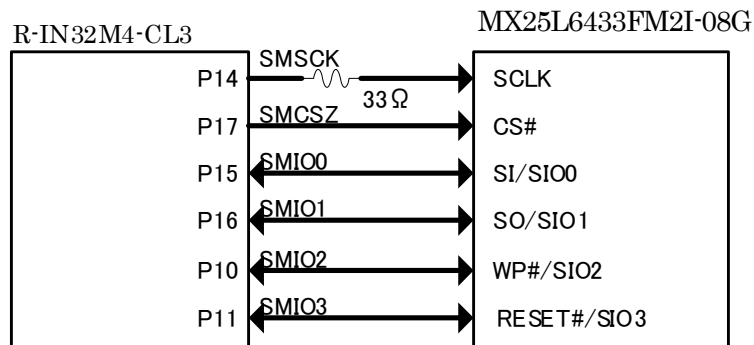

4.5. I2C Interface

R-IN32M4-CL3 is connected to the header, enabling I2C synchronized communications (2 channels). A 4 x 1 pin header (2.54 mm pitch) is available for I2C interface.

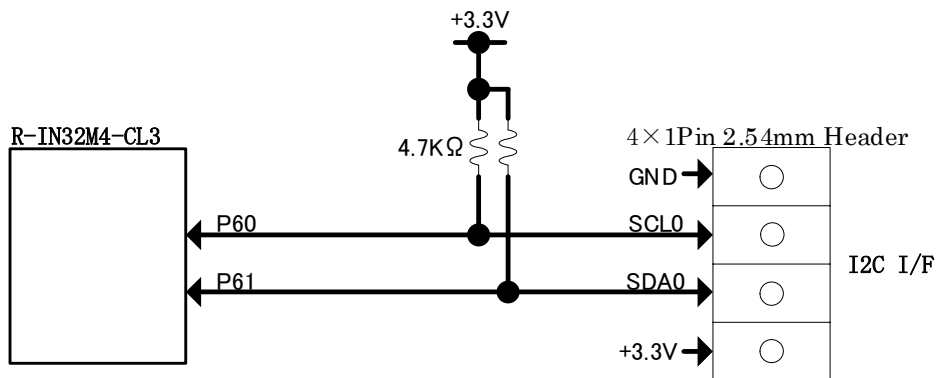

4.6. CSI Interface

R-IN32M4-CL3 is connected to the header, enabling synchronous serial communication.

Two 5 x 1 pin headers with 2.54 mm pitch are available for CSI interface.

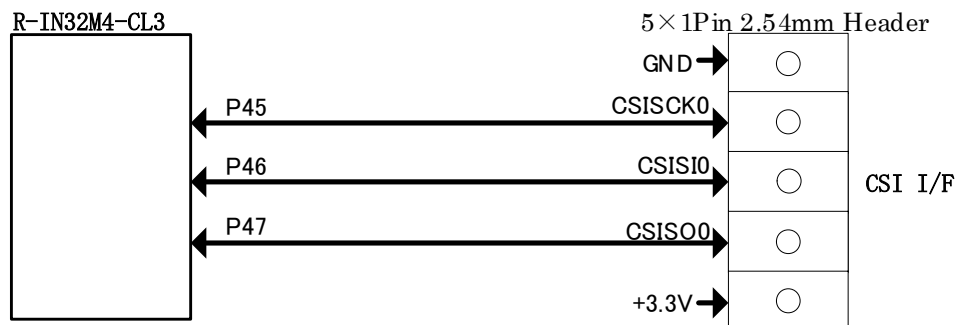

4.7. RS-485 Interface

R-IN32M4-CL3 is connected to the header, enabling RS-485 communication.

To perform RS-485 communication because a UART signal is assigned to the header

An external transceiver circuit must be built.

The connector is equipped with a 5x1Pin 2.54mm Header.

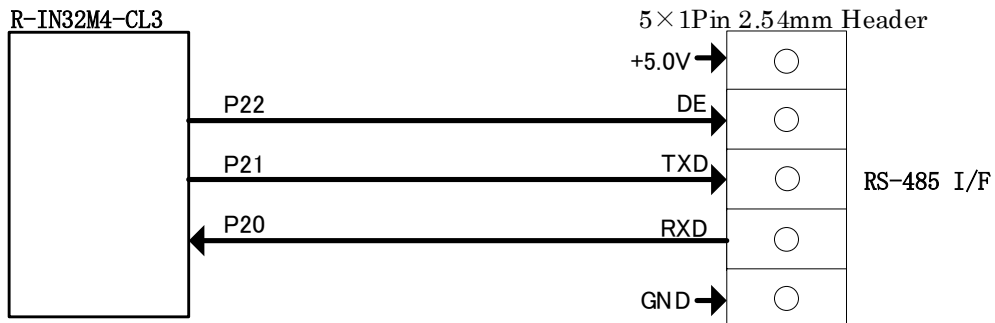

4.8. UART Interface

The board offers a UART-to-USB chip for the UART function (FT232RQ) and a USB connector, supporting PC communication in asynchronous mode.

A USB micro-B connector is mounted for UART interface.

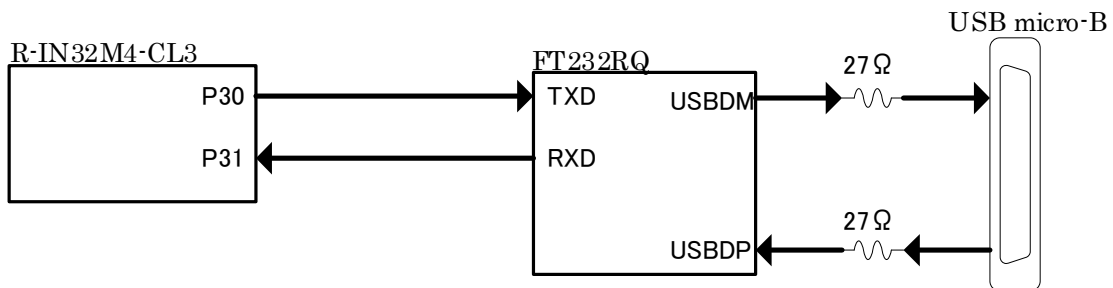

4.9. General-Purpose I/O

The following shows the DIP-SW (input), LED (output) to the R-IN32M4-CL3 general-purpose ports.

General-purpose DIP-SW input (4 bits)

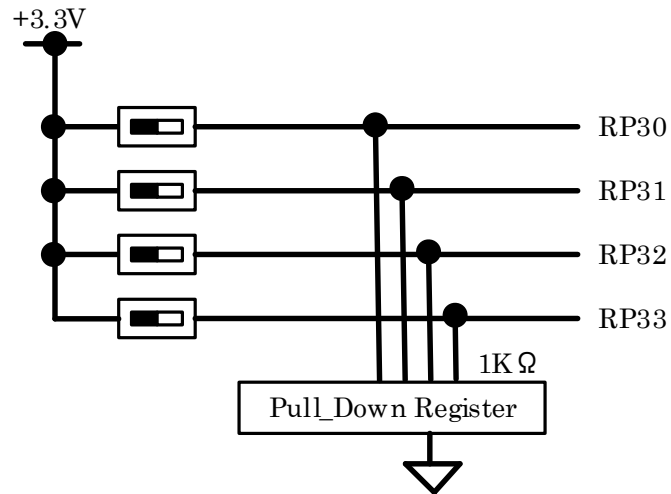

General-purpose LED output (4 bits)

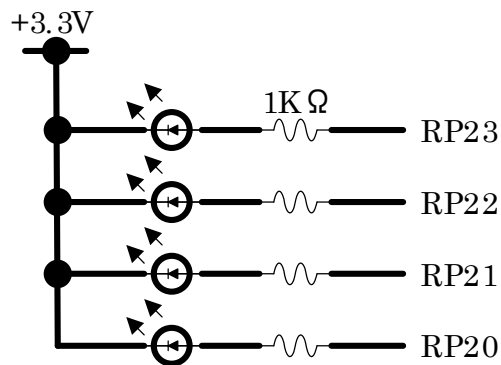

4.10. CC-Link IE TSN / CC-Link IE Field Interface

CC-Link IE TSN and CC-Link IE Field communication

This is performed using the RJ45 connector with a built-in pulse transformer.

Two channels of RJ45 connectors are mounted.

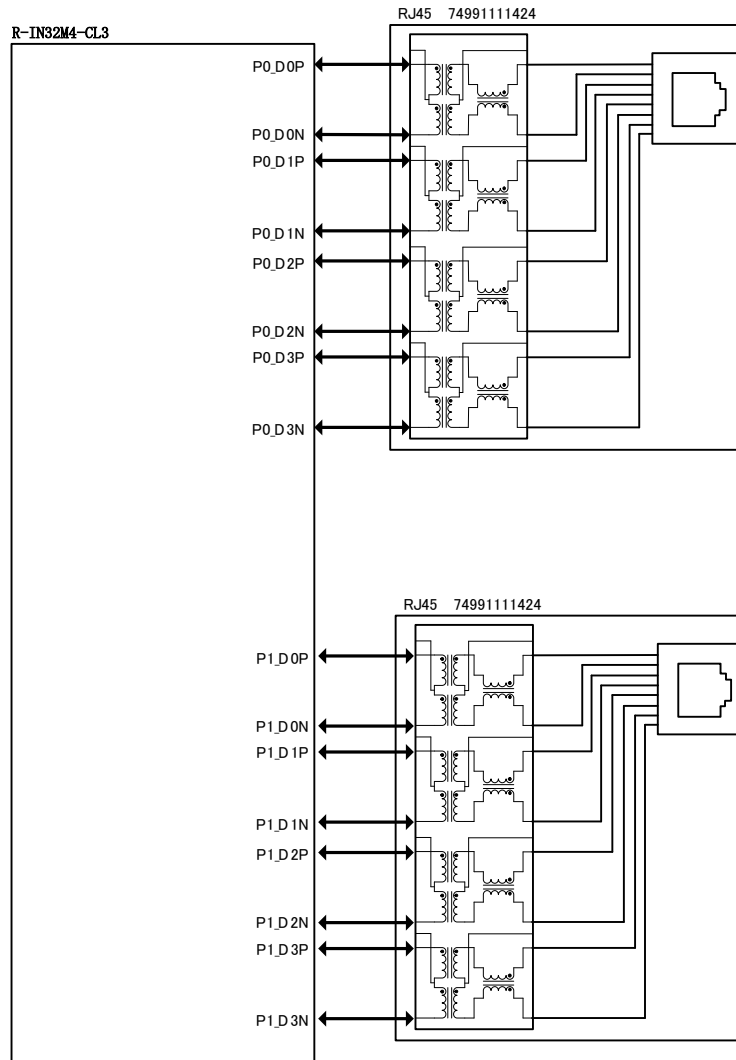

4.11. Power Supply

Input 5V from AC adapter, USB, ICE, and "3.3V, 1.15V" with power supply IC is being generated.

The LED (green indicates power supply) lights up when 5V are applied.

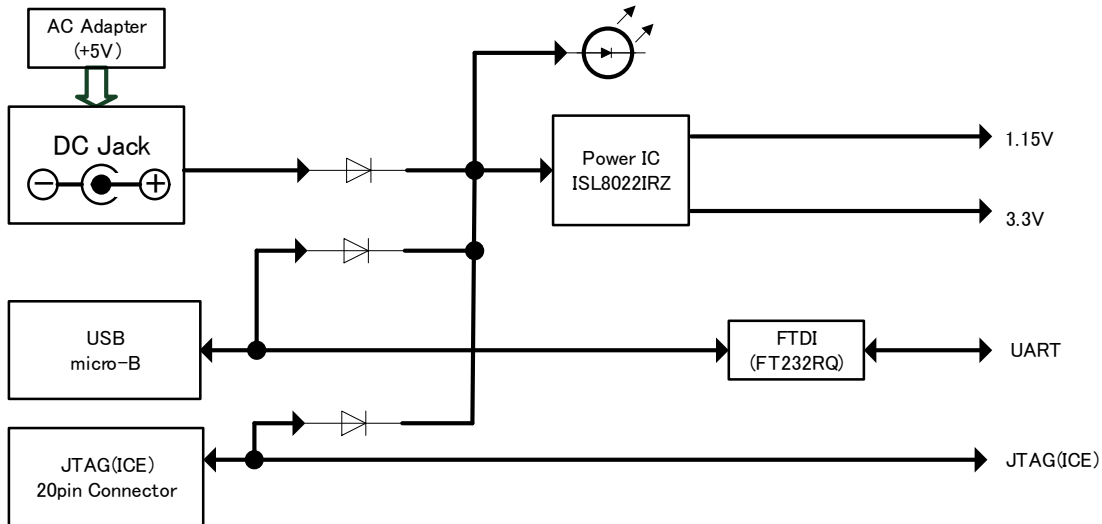

4.12. Reset

When the board is powered, push the reset button (SW13) or apply a reset signal via the ICE connector, to reset all board resources.

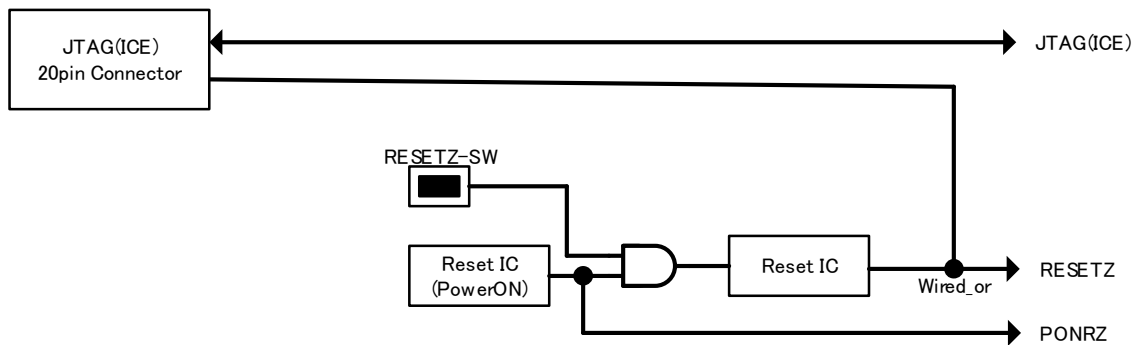

4.13. Clocks

This evaluation board provides the following clocks: R-IN32M4-CL3 system clock (25 MHz) and CC-Link IE TSN / CC-Link IE Field clock (2.097152 MHz).

*Oscillation stabilization period for each oscillator: 10ms.

* CC-Link IE Field clock (2.097152MHz) is not implemented.

* When using CC-Link IE Field, select the internal oscillator circuit.

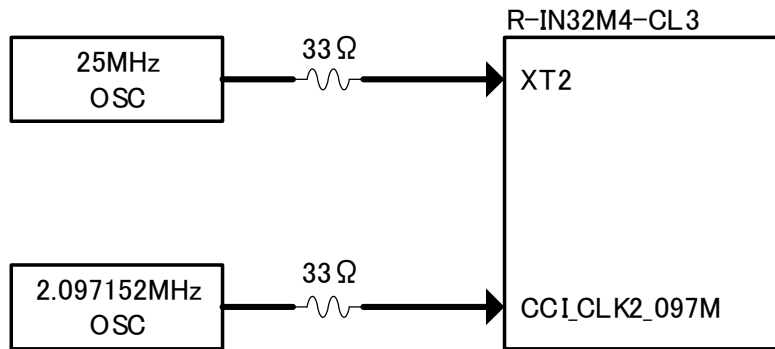

5. DIP, Rotary, and Push Switch Configurations

5.1. SW1: Mode Setting

Board Silk: SW1

Part #: WURTH 416131160802

2-bit DIP-SW connected to R-IN32M4-CL3 for operation mode selection.

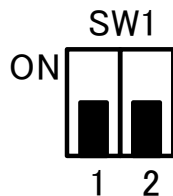

SW1	Level	Terminal name	Boot mode selection setting
1	L	BOOT1	External serial flash ROM boot
ON	H		Instruction RAM boot
SW1	Level <th>Terminal name</th> <th>2.097152MHz Clock selection setting</th>	Terminal name	2.097152MHz Clock selection setting
2	L	CLK2MSEL	External
ON	H		Internal

* Default factory setting: 1-OFF / 2-ON

5.2. SW12 General-Purpose Port DIP Switch

Board Silk: SW12

Part #: WURTH 416131160804

4-bit DIP-SW connected to R-IN32M4-CL3 for general-purpose input.

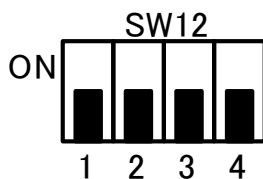

Terminal No.	Terminal name
1	RP30
2	RP31
3	RP32
4	RP33

* Default factory setting: all OFF positions

5.3. SW3 / SW5 CC-Link IE TSN IP address Selection Rotary Switches /

CC-Link IE Field Station Number Selection Rotary Switches

Board Silk: SW3, SW5

Part #: COPAL SC-1110

16-position, real-code rotary SW connected to R-IN32M4-CL3 for selecting
Set the IP address of CC-Link IE TSN / Set the Station Number of CC-Link IE Field.

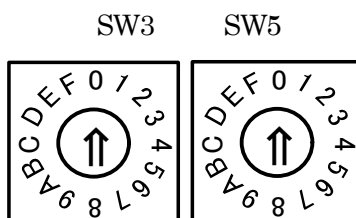

SW	Code	Position														Terminal name		
		0	1	2	3	4	5	6	7	8	9	A	B	C	D		E	F
SW3	1		●		●		●		●		●		●		●		●	P14
	2			●	●			●	●			●	●			●	●	P15
	4					●	●	●	●					●	●	●	●	P16
	8									●	●	●	●	●	●	●	●	P17
SW5	1	●			●		●		●		●		●		●		●	P10
	2		●	●			●	●			●	●			●	●		P11
	4					●	●	●	●				●	●	●	●		P12
	8									●	●	●	●	●	●	●	●	P13

* Default factory setting: SW3- Position “1” / SW5- Position “2”

5.4. SW13 Reset Push Switch

Board Silk: SW13

Part #: COPAL SKQMBBE010

SW13 is tact switches (PUSH-SW) connected to the I/O ports of the R-IN32M4-CL3 chip.

These switches are used to input resets (RESETZ).

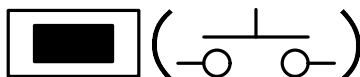

6. LED

6.1. Power Supply

Board Silk: D49 (POWER)

Part #: ROHM SML-D12P8W

This is a green LED (1 bit) for monitoring the power supply.

6.2. LEDs for Monitoring CC-Link IE TSN / CC-Link IE Field Operations

Board Silk: See list below

Part #: ROHM SML-D12P8W, SML-D12U8W

These are green LEDs (7 bits) for monitoring CC-Link IE TSN / CC-Link IE Field operations.

*The LED turns on when port is set to Low.

LED01: RUN	(Green)
LED02: D.LNK	(Green)
LED03: ERR	(Red)
LED04: L.ERR	(Red)
LED05: L.ERR2	(Red)
LED06: IE_SD	(Green)
LED07: IE_RD	(Green)

6.3. General-purpose LED

Board Silk: LED10 / LED11 / LED12 / LED13

Part #: ROHM SML-D12P8W, SML-D12U8W

Green & Red LED (4 bits) connected to R-IN32M4-CL3 for general-purpose output.

7. Connector Pin Definitions

7.1. I2C Connector

Board Silk: CN7

Type: 4 x1 pin header, 2.54mm pitch

*Not Mounted



Terminal No.	I/O	Terminal name	R-IN Signal name
1	-	GND	-
2	I/O	SCL0	P60
3	I/O	SDA0	P61
4	-	+3.3V	-

7.2. CSI Connector

Board Silk: CN6

Type: 5 x1 pin header, 2.54mm pitch

*Not Mounted



Terminal No.	I/O	Terminal name	R-IN Signal name
1	-	GND	-
2	I/O	CSISCK0	P45
3	I	CSISI1	P46
4	O	CSISO1	P47
7	-	+3.3V	-

7.3. RS-485 Connector

Board Silk: CN12

Type: 5 x1 pin header, 2.54mm pitch

*Not Mounted



Terminal No.	I/O	Terminal name	R-IN Signal name
1	-	+5.0V	-
2	I/O	DE	P22
3	I	TXD0	P21
4	O	RXD0	P20
7	-	GND	-

7.4. UART (USB) Connector

Board Silk: CN8

Type: USB micro-B

Part #: WURTH 629105150521

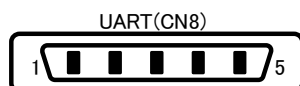

Terminal No.	I/O	Terminal name
1	-	(VBUS)
2	-	(ID)
3	I/O	D+
4	I/O	D-
5	-	GND

7.5. CC-Link IE TSN / CC-Link IE Field Connector

Board Silk: CN3 / CN4

Type: RJ45, 2 units

Part #: WURTH 7499111424

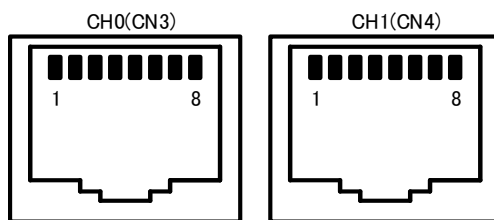

Terminal No.	I/O	Terminal name	PHY Signal name
1	I/O	MX1+	MDI[0]+
2	I/O	MX1-	MDI[0]-
3	I/O	MX2+	MDI[1]+
4	I/O	MX3+	MDI[2]+
5	I/O	MX3-	MDI[2]-
6	I/O	MX2-	MDI[1]-
7	I/O	MX4+	MDI[3]+
8	I/O	MX4-	MDI[3]-

7.6. JTAG (ICE) Connector

Board Silk: CN1

Type: 10 x 2 pin header, 1.27mm pitch

Part #: SAMTEC ASP-185676-01(SHF-110-01-L-D-SM)

*To prevent incorrect insertion, the 7th pin has been removed.

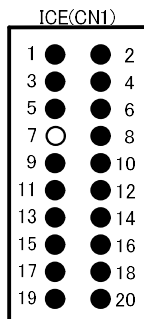

Terminal No.	I/O	Terminal name	R-IN Signal name	Terminal No.	I/O	Terminal name	R-IN Signal name
1	-	(Vtref)	-	11	-	TgrPwr	-
2	O	TMS	TMS	12	I	TRACECLK	TRACECLK
3	-	GND	-	13	-	TgrPwr	-
4	O	TCK	TCK	14	I	TRACEDATA0	TRACEDATA0
5	-	GND	-	15	-	GND	-
6	O	TDO	TDO	16	I	TRACEDATA1	TRACEDATA1
7	-	-	-	17	-	GND	-
8	I	TDI	TDI	18	I	TRACEDATA2	TRACEDATA2
9	-	GND	-	19	-	GND	-
10	O	nRESET	TRSTZ	20	I	TRACEDATA3	TRACEDATA3

7.7. DC Power Jack

Board Silk: CN11

Type: DC power jack

Part #: WURTH 694106301002

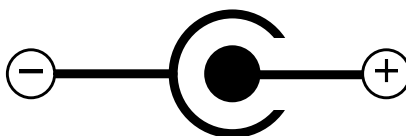

8. Table of Pad Connection Pins

8.1. PAD Connection Pins

The following pins are connected from R-IN32M4-CL3 and other chips to probing pads.
PAD: 0.8mm pad (DIP)

Terminal name	PAD name	Terminal treatment
CCI_CLK2_097M	CLK209	-
XT2	CLK25	-
XT1	XT1	Pull-down
NMIZ	NMIZ	Pull-up
PONRZ	PONRZ	Pull-up
RESETZ	RESETZ	Pull-up
Power	V5	-
	V11	-
	V25REG	-
	V33	-
GND	GND1	-
	GND2	-

9. Default Factory Settings

The following section provides the default settings of the DIP-SW, Rotary-SW, and jumpers.

9.1. DIP-SW/Rotary-SW

SW	Set value
SW1	1-“OFF” / 2-“ON”
SW3	Position 1
SW5	Position 2
SW12	All OFF

5. Board External Diagram

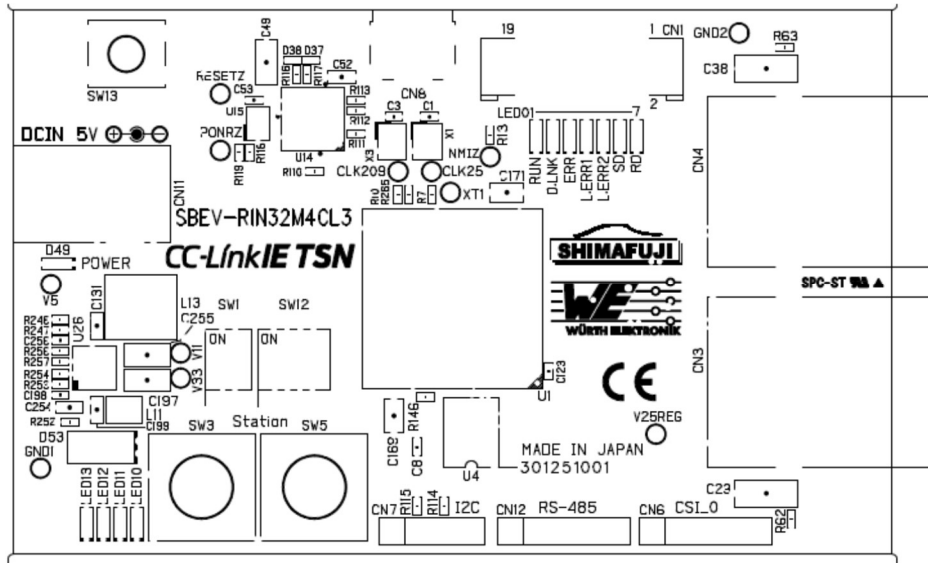

Figure 9a Board Component Side

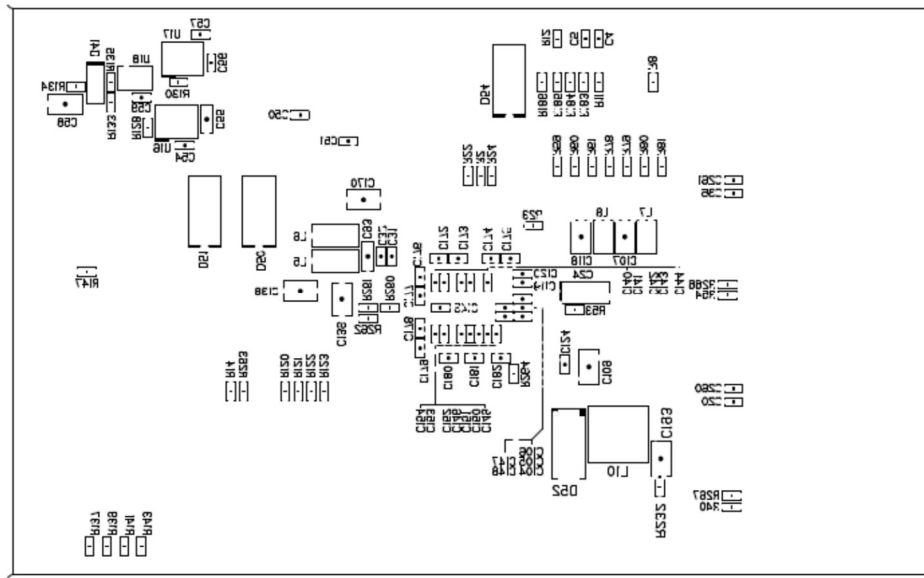

Figure 9b Board Soldering Side

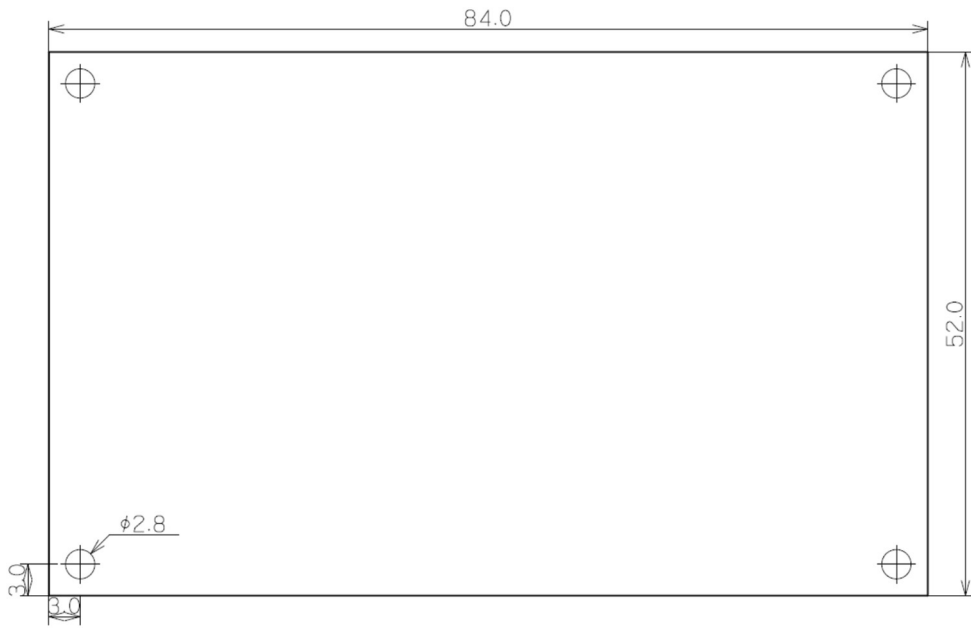

Figure 9c Dimensional